

# CONSERVING HISTORIC SIGNS

## CONSERVATION GUIDELINES FOR HISTORIC SIGNS AND NEW SIGNS ON HERITAGE BUILDINGS

---



RACHEL JACKSON & CAROLINE LAWRENCE



## CONSERVING HISTORIC SIGNS; CONSERVATION GUIDELINES FOR HISTORIC SIGNS AND NEW SIGNS ON HERITAGE BUILDINGS

These guidelines were prepared in April 2002 for the Heritage Office by Rachel Jackson and Caroline Lawrance as part of a project funded by the Heritage Incentives Program.

© State of New South Wales through the Heritage Office, Department of Planning, 2006. You may copy, distribute, display, download and otherwise freely deal with this work for any purpose, provided that you attribute the Heritage Office, Department of Planning, as the owner. However, you must obtain permission if you wish to: (1) charge others for access to the work (other than at cost); (2) include the work in advertising or a product for sale; or (3) modify the work.

### **Disclaimer**

This document has been prepared by the Heritage Office, Department of Planning, for general information purposes. While every care has been taken in relation to its accuracy, no warranty is given or implied. Recipients should obtain their own independent advice before making any decisions that rely on this information.

First published 2006

ISBN 1 921121 06 8

HO06/09

NSW Heritage Office  
Locked Bag 5020  
Parramatta NSW 2124  
Tel: (02) 9873 8500  
Fax: (02) 9873 8599  
[www.heritage.nsw.gov.au](http://www.heritage.nsw.gov.au)

Cover: *His Master's Voice* painted on the side wall of the EMI building in Castlereagh Street, Sydney.  
Photograph taken in 1996, before the sign was covered up in 1998.

**TABLE OF CONTENTS**

**1 INTRODUCTION.....1**

1.1 Author Identification .....1

1.2 Methodology & Research Development .....1

1.3 Acknowledgments.....1

1.4 Background .....2

1.5 Definitions .....3

1.5.1 Definition table.....3

1.5.2 Location .....4

**2 ASSESSMENT OF SIGNIFICANCE .....5**

2.1 Identification of cultural significance .....5

2.2 Understanding Significance .....5

2.2.1 Historic significance .....5

2.2.2 Social significance .....8

2.2.3 Aesthetic significance .....9

2.2.4 Technical / research potential .....10

2.2.5 Comparative value .....11

**3 CONSERVATION .....14**

3.1 Conservation of signs with historic significance .....14

3.2 Approach to conservation .....14

3.3 Summary of conservation approaches .....19

3.4 Examples of practical conservation to historic signs .....19

3.4.1 Market signs, Haymarket, Sydney .....19

3.4.2 The Bushells Building, the Rocks, Sydney .....21

3.4.3 The School of Arts Building, Sydney .....22

**4 NEW SIGNS ON HERITAGE BUILDINGS .....23**

4.1 Minimise the impact of new signs .....23

4.2 New signs .....23

4.2.1 Styles and design .....23

4.2.2 Traditional style .....23

4.2.3 Contemporary style .....23

4.2.4 Lettering .....23

4.2.5 Location .....24

4.2.6 Controls .....24

**5 REFERENCES .....25**

---



## 1 INTRODUCTION

This document has been produced as a project funded by the NSW Heritage Assistance Programme, 1998. The document is set out into the following parts:

1. INTRODUCTION: background and definitions of the guidelines.
2. ASSESSMENT AND SIGNIFICANCE: to identify the potential cultural significance of signs.
3. CONSERVATION: approaches to the conservation for historic signs with cultural significance.
4. NEW SIGNS ON HERITAGE BUILDINGS: to minimise the impact of new signs on the cultural significance of heritage buildings and conservation areas.

The guidelines have been developed to assist property owners, heritage practitioners, heritage advisers and local government agencies to identify and assess the potential cultural significance of historic signs and to assist in the management and conservation of significant signs. It also offers guidelines for new signs on heritage buildings.

### 1.1 Author Identification

The report has been written by Rachel Jackson, heritage specialist, working with the Australian Heritage Commission and Caroline Lawrance, heritage specialist, builder and architect, working with the National Parks and Wildlife Service (NSW). Both Rachel and Caroline completed a Masters in Heritage Conservation from the University of Sydney in 1996. Rachel's Research Report for the Masters degree was a study of historic painted signs and their need for recognition in the heritage industry<sup>1</sup>. The Report was inspired by Caroline's photographic record and interest in historic signs over a number of years.

Contribution to the Section 3 of the text was provided by Cathy Lilico Thompson. Cathy is a conservator from the International Conservation Services Pty Ltd and worked with Rachel Jackson in her previous position at Tanner & Associates Pty Ltd, heritage architects, on the conservation of the University of Technology, Sydney, Haymarket Campus historic signs and the Bushell's Building signs, included in the examples in Section 3.

All photographs included in this document have been taken by Rachel Jackson and Caroline Lawrance unless otherwise stated.

### 1.2 Methodology & Research Development

The methodology for conservation of historic has been developed following the Australia ICOMOS Burra Charter. The basis for assessment of cultural significance has also been developed following the Assessment Guidelines from the NSW Heritage Office Heritage Manual.

The guidelines document has been based on the thesis developed by Rachel Jackson in her Research Report, the '*Conservation of Historic Painted Signs*,' for the Masters of Heritage Conservation from the University of Sydney, 1996. The outcome of the thesis was the need for recognition of the importance of historic signs by the heritage industry and the ultimate need for conservation of significant signs. The guidelines were considered necessary following positive feedback from the public and heritage practitioners due to media attention and also from a talk given by the authors at the National Trust of Australia (NSW) in 1998. Also, given the amount of interest gathered by the authors over the last 5 years, it is believed that the retention and conservation of historic signs appears to be a growing concern for local historical societies, local council staff, heritage advisers and heritage practitioners.

### 1.3 Acknowledgments

The following people and organisations have greatly assisted in the development of these guidelines:

NSW Heritage Office – Elisha Long and Susan Macdonald  
National Trust of Australia (NSW)  
Trevor Howells, Department of Architecture and Planning, University of Sydney  
Richard Lamb, Department of Architecture and Planning, University of Sydney

---

<sup>1</sup> Jackson, R., (1996) '*Conservation of Painted Signs*', available at the University of Sydney, Architectural Resource Library.

Megan Jones, Associate Director, Tanner & Associates Pty Ltd, Architects  
Cathy Lilico-Thompson, Conservator, International Conservation Services, Pty Ltd  
Peter McKenzie, Director, Jackson Teece Chesterman & Willis Pty Ltd, Architects & Planners.

#### 1.4 Background

*“Historic signage, which forms an integral part of a building or structure may have its own significance that should not be devalued by later signage. For instance, some of the old painted signs that remain above awnings in country towns are designed period pieces that should be retained. Replicas of old signs are often impractical and costly as well as being fakes. In some cases reconstruction can be justified if the new sign maintains a connection with a previous important occupant or use of the place. In others the sign itself may have some heritage value which justifies reconstruction.”<sup>2</sup>*

Historic signs are an important cultural heritage resource and the conservation of significant painted signs or name signs should be considered by property owners, heritage practitioners and government authorities. They are a resource which gives insight into our society over the past two centuries more than just the physical and historical records of a building. Some historic signs have become part of a cultural landscape and have value within a contemporary community, often more so than the physical limitations of a structure or town. Signs may contribute to understanding the social value of a place or heritage building.

Traditionally signage was painted on or built into buildings as advertising or as name signs (refer to Section 1.5 Definitions). In broad terms there was an integration of signage with the building, or sometimes they were painted to be eye catching and could cover a large area on a side wall of a building, depending on the nature of the building. Photographs from the end of the nineteenth century through to the twentieth century attest to a vibrant and sometime dominant display of signs covering city and streetscapes. Old photographs show that signs were painted on walls, parapets, panels, verandahs and awning fascias or directly onto glazing.

Signs and sign writers utilised a variety of styles and techniques which were often tailored to display individual characteristics of a sign writer. In general, sign writing is a technical skill and has often been considered an art form. However this skill is in danger of rapidly dying out with the advances in computer and photographic technology. Historic signs and sign writing images of the past are becoming increasingly rare.

Name signs are either built into the fabric, painted or are applied to a building. Name signs, often intrinsic to the significance of a building, are vulnerable to changing building owners, for example Banks, Post Offices and other government owned buildings. Advertising signs, generally painted on side walls and parapets of buildings, often go unnoticed because they have faded, or no longer have commercial value, or are often not known about until exposed on a side wall after a neighbouring building has been demolished. While other types of advertising signs built on free-standing structural frames, such as neon signs and service station signs, still exist as an advertising technique, there are a number of these signs which have become landmarks and part of the cultural landscape.

Where it is possible, it is now the responsibility of heritage practitioners to identify and conserve this threatened aspect of our social history.

---



<sup>2</sup>

Conservation Areas, NSW Heritage Office, p.46.

## 1.5 Definitions

### 1.5.1 Definition table

The following definition table provides an indication of where historic signs may be found.

TYPE	DEFINITION	POSSIBLE LOCATION	EXAMPLE
<b>NAME SIGNS</b>			
Moulded / Relief / Engraved	Permanent, cut into stone or render, or typical building material. Normally the name of a building and/or the date.	Pediment block above cornice, frieze panel or wall below cornice, frieze panel above ground floor.	 <p>Griffiths Tea Building, Surry Hills, 1996.</p>
Applied / Raised	Cut out lettering, e.g. timber or brass fixed to wall.	Free standing structures along the road side or on top of buildings.	
Painted	Painted lettering and/or graphics.		
Freestanding	Lettering and graphics, often illuminated with coloured neon lighting.		
<b>LETTERED WINDOWS</b>			
Advertising / Motifs	Painted on glass – shop windows. Gilded letters on stipple background	Shopfronts (glazed panels), frieze panels above doors – fanlight, windows, side panels, etc	 <p>Evans Street, Rozelle, 1995.</p>
<b>PAINTED GENERAL</b>			
Logos / Generic labels/ Pictorial images / Advertising	Painted directly onto the building fabric – timber, masonry, steel, corrugated iron. Usually commercial.	Carcass of building, building fronts, street facade, side walls, designated areas (sign fields, e.g. parapet, pediment and verandahs)	 <p>Rail bridge, Strathfield, 1997.</p>
Painted panels	Freestanding painted signs fixed to part of a building. Billboards		

### 1.5.2 Location

Possible sign locations:

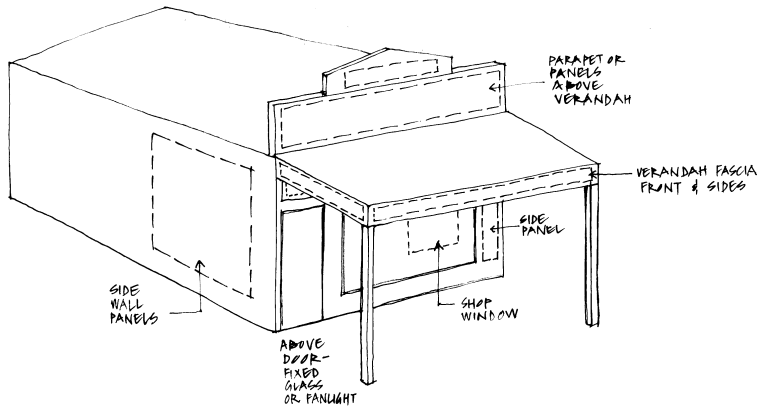
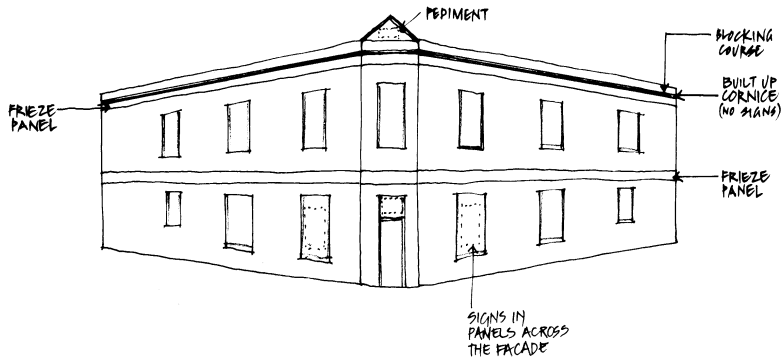



## 2 ASSESSMENT OF SIGNIFICANCE

### 2.1 Identification of cultural significance

Historic signs can be important for understanding our cultural heritage and therefore their identification is necessary. Culturally significant signs can be treated as an individual heritage item or as an element of a significant building which has (generally) already been established as a heritage item.

Where a historic sign (or signs) may have potential cultural significance and is considered a potential heritage item, the assessment and management guidelines of the NSW Heritage Manual (1996), prepared by the NSW Heritage Office, should be used.

A historic sign may not be individually significant but may be associated with a culturally significant building or conservation area. In these cases the historic sign(s) should be considered with conservation management polices for heritage buildings or conservation areas.

Heritage practitioners, local heritage advisers, government authorities and community members concerned about the future of historic signs should draw attention to the potential significance of historic signs known to them and actively participate in retaining them for future generations.

### 2.2 Understanding Significance

The following assessment method, based on the NSW Heritage Office Assessment Guidelines, provides a guide for developing an understanding of the potential significance of historic signs and an example of how a heritage practitioner might go about an assessment of significance for historic signs. This is important to have an understanding of significance of signs before specifying a conservation approach or method of repair.

Also, it is important to establish the relationship of the historic sign to the building it is on, or the place it is most likely to be associated with. For example the following questions should be asked:

5. Is the building a heritage item enabling the sign to be recognised as part of the building's significance?

In this case the sign will become a part of the conservation management policies for that building or site. Ideally the conservation approach assigned to a sign will be directly related to its established significance within the total scheme of a conservation project. The conservation will become dependent on any number of requirements related to the conservation of the building.

- Is the historic sign likely to be significant in its own right?

If so, the assessment of significance should be undertaken following the NSW Heritage Office Assessment Guidelines, as would be applied to any potential heritage item. The approach and practical application of conservation should follow these guidelines and the methodology of the Australia ICOMOS Burra Charter.

#### 2.2.1 Historic significance

Some signs can provide evidence of our evolving pattern of cultural history and are likely to be of historic significance.

Name signs are intrinsic to the fabric of a building and are directly related to the history of a building. Painted advertising signs could be considered historically significant through the message contained in the sign and by the art of the sign painting / writing itself. Sign painting or sign writing is a rapidly dying art form / technique. No longer do painted signs appear in the vast quantities that once covered the streetscapes of urban life. The historic evidence for the extent of sign writing is in abundance, for example archival photographs of Sydney show signs of all styles on a vast number of buildings. However, while historic signs are still evident they are not always at the scale or pictorial quality of the past. They have become historically significant.



A historic sign from 1899, painted on the side of a building wall in George Street, Sydney (the building has been demolished). Sydney City Archives.



A photograph taken by Olive Cotton, 1942, from Max Dupain's Studio window, in Clarence Street, Sydney.

A particular era can be identified in a sign through its message and the technique used to apply or create the sign and the significance could also be established in 'social' or 'aesthetic' significance categories. Like most heritage items, however, it is not just the era they represent but the level of cultural significance they may display that should be assessed.

The associations of a sign to a building, or message contained within a sign, may give rise to different interpretations of historic value and the following examples are indications of how to establish historic significance.

1. The sign on a building is not necessarily a historic event, but may represent a historic phase in the building's life.

The Sydney School of Arts Building in Sydney, has not been used as a School of Arts for decades, however it has been conserved and adapted as part of a neighbouring tower development. As well as a name sign engraved in the stone pediment of the Pitt Street facade, a painted sign advertising the building and its opening hours remains on the side wall (below left). This sign has been restored as part of the building's history, even though its use has changed. Refer to the examples in Section 3.



Sydney School of Arts, Pitt Street, 1998, before restoration.



2KY - wireless, Sussex Street, Sydney, 1996.

2. The message in a historic sign may also be descriptive of an important event or phase of activity. The sign may not be directly related to the significance (or lack there of) of the building.

The 2KY-wireless sign (above right), represents a promotion campaign run in the 1970s and it has remained on the building long after the event, it is now a historical record. The use of the word 'wireless' and the pictorial record of a kookaburra are historically and socially significant – the sign itself has become an icon and landmark in the cityscape. The building on the other hand, may not be considered significant and therefore poses questions regarding the conservation of the sign.

- A historic sign may also directly relate to the significance of an identified or potential heritage item.

The Bushells Building in the Rocks, although no longer owned by Bushells, has remnant painted signs on the major facades of the building relating directly to the Bushells use within the building and also advertising its products. Refer to example in Section 3.

The Rex Simpson sign is directly related to the historical use of the building, a significant building located in George Street, Sydney. The building became known as 'Simpson House' because of its use as a men's clothing store by the same name. The signs (one on both sides of the building) have a direct relationship to the former use of the building and now that use has gone the historical importance is reconfirmed by the signs. It also demonstrates a particular era in men's fashion of the 1950s.



*Bushells Building, The Rocks, the south facade, with a number of layered signs, 1996.*

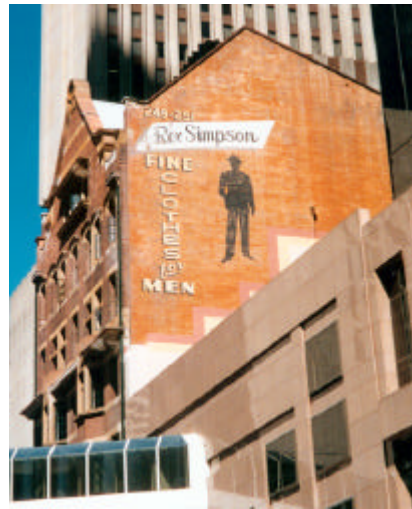

*Advertising sign for 'Rex Simpson fine clothes for men' s painted in the 1950's on 'Simpson House' in George Street. 1996.*

- A sign may be historically significant in its own right and give its host building greater significance or appreciation of its own past history, like a post office or bank.

A sign, or a combination of signs, on an old corner shop, which no longer functions as such, provides an insight into the building's past history and the role of the corner store in suburban areas.

Government buildings, like post offices and customs houses, are being sold and the symbols which once inspired a community conscience and sense of identity are being lost. The extant signs are reminders of the building's importance.



*Post Office in Erskineville,, recently restored for residential use. The owners have retained the old post office signs. 1998.*



*Corner Store in Abbotsford. Corner stores are becoming redundant and the historic signs are an important reminder of these buildings. 1996.*



*Old corner store in Paddington, with an array of fading signs. 2000.*

## 2.2.2 Social significance

Historic signs may be important because they can contain evidence of a social, spiritual or cultural association with, or held by, a particular community.

Signs can inspire a sense of sentiment in the community as well as adding to a community's sense of identity. This is particularly evident in small towns and is often identified in conservation areas.

Historic signs can be an evocative picture of the past, at the top level displaying the cultural climate of a particular era, either economically, politically, socially, scientifically. This can be seen through images of election campaigns, war notices for help in the war effort, graffiti through to advertising products like soap and tobacco.

Social value is also closely linked to historic value in the discussion of historic signs. A historic sign could provide clues to our social history as the development of our consumer society can be pieced together. They can also assist in retaining the community's sense of identity with the past and in understanding an evolving pattern of cultural history which can be obtained through the message of signs. The following images are advertising products which are no longer being promoted today.

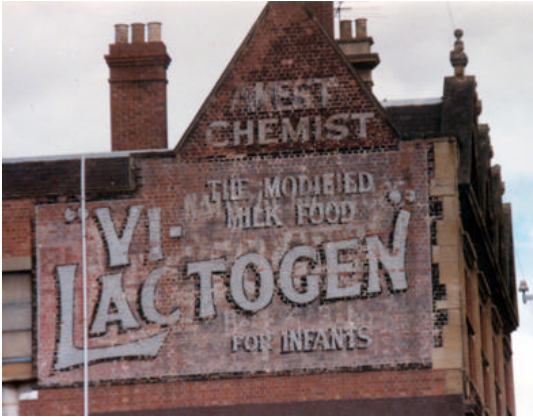

'Vi-lactogen', a baby health product, Fitzroy Melbourne, 1982. This sign is still evident today.



'Indian Root Pills', an indigestion remedy. The sign was exposed in 1999 on the side of a building in Cremorne, Sydney. It has since been covered up by a new building. Photo: Megan Jones, 1999.



'Briquettes' – used for coal fireplaces and water heaters. Melbourne 1982.



'Velvet Soap' – a family favourite. Melbourne 1982.

### 2.2.3 Aesthetic significance

Historic signs have aspects which inspire a strong visual and sensory appeal through proportion, style and pictorial presentation and execution. Advertising and name signs are often located on buildings where they are obvious to a passer-by and some have been designed to complement the architectural style of the building.

The past art of sign writing and large pictorial painting is not found nor commissioned by advertising companies today. The original intention of large signs was to be eye catching, and they were painted onto the most prominent position of buildings, located on structures like rail bridges or in the case of neon signs, erected on the top of buildings. Therefore quite often signs will have landmark qualities for this reason. These signs can be considered to have creative and technical excellence, for sheer scale and quality of craftsmanship or engineering found in pictorial advertising.



*The 'His Masters Voice' sign, Goulburn Street Sydney, whilst it was painted on the side of the EMI building – a subsidiary company of HMV, the sign itself is symbolic and is a largely recognisable symbol at an international level – the dog, Nipper, in front of the gramophone. The sign also displays technical significance, by its large graphic presentation. The photograph was taken in 1996 and a new building has since covered the sign.*

On the other hand, name signs were designed to be intrinsic to the fabric of the building and the design is a conscious feature of the building's aesthetic – sometimes discreet, but always complementary to the building.

#### **2.2.4 Technical / research potential**

Historic signs can provide evidence of technique, design styles and methods of painted styles. With neon signs, they represent a particular evolutionary era of electric signage. They can also provide evidence of cultural patterns through the messages contained within the signs and therefore have research potential.

A study of historic signs and their meaning in our society can become a research topic in itself. However sign style and sign writing methods are likely to provide information about who created the signs, how and when. This information is important for future generations of sign writers (and conservators) to continue and conserve the tradition.



*'Travel by Air - 5 to Bourke' from Gilgandra, NSW. Photo: Arnold Walters, Gilgandra Heritage Adviser, 1999.*



*'We Write Signs', 408 Elizabeth Street, Sydney, 1917 (demolished). Sydney City Council Archives.*

Names signs on buildings can also be as elaborate as the building itself, particularly buildings of a highly ornate style. The signs are designed to be a confirmation of the building's importance and prestige and can provide information about the building and the company which commissioned the building.

### 2.2.5 Comparative value

In addition to the four value criteria outlined above, there are two criteria for assessing the degree of significance of different items. The NSW Heritage Assessment Guidelines have two value criteria, rare and representative, which are considered against the four 'nature of significance' criteria, already discussed.

'Representative and rarity' values will generally cover a comparative analysis with other historic signs. The rarity value is described as representing a rare, endangered or unusual aspect of history, while representativeness illustrates an important class of historic items. The rarity or representative type could be classified by the information already available about the sign. A comparative analysis could also be undertaken against types of signs advertising the same products. For example this study has demonstrated that there are many extant 'Shell' signs, 'Kinkara Tea' and 'Bushells Tea' images.



*'Shell Motor Oils', Melbourne, 1982.*



*'Shell', an old service station sign, south coast NSW. (Photo: Matthew Cooper, 1998)*



*A 'Kinkara' tea sign in Marulan, NSW, could be compared to another Kinkara sign to be assessed for its representative or rarity values or for a comparative analysis. 1999.*



*A 'Kinkara' tea sign on an old corner store in Chelmsford Street, Newtown, 1998.*



*A Bushells sign in Tasmania, c1980s could be compared to another Bushells sign. A comparative analysis could be undertaken to establish the period it was painted in.*



*Another Bushells sign in Tasmania, c1980s, using the same style as the image opposite, adapted to fit the building. Note the spelling of 'Flavor'.*

The relative rarity or representative value of a sign should be individually tested in each case.

For example the market signs on the old facade of the University of Technology, Sydney (UTS) library, are considered rare. Originally, in the Haymarket area, there were numerous market signs, all of a similar style, however with their removal resulting from major development and changes in Haymarket area. All the original signs have been removed with the exception of the group of signs on the remnant market facade of the UTS campus in Quay Street, Haymarket. The UTS old market signs are now considered rare, however individually assessed against one another they could be considered representative of a type.





*Old market signs at the UTS campus in Quay Street, recently conserved due to their historic significance and rarity value, 1999.*



*Image of Quay Street, Haymarket in the early 1960s. Sydney City Archives.*

In conclusion, to complete the assessment of a historic sign and to establish it as a heritage item, the appropriate level of significance should be established. The levels of significance applying to items in NSW are local, state, national, and international. In NSW there are two statutory registers, the State Heritage Register and schedules of local or regional environmental plans. To be listed in the State Heritage Register a heritage item would have to be rated as being of State significance, which can be judged against the State Heritage Register criteria. However, signs may be considered for inclusion in the State Heritage Inventory if they are identified as having heritage values.

There are other non-statutory registers including the National Trust of Australia Register, the Register of the National Estate and many others related to professional bodies, such as the Royal Australian Institute of Architects. Currently the National Trust of Australia (NSW) Register has included historic signs on its list. In addition the Victorian Heritage Register includes a number of signs (mainly neon signs) considered to be of State significance. More information can be obtained from the NSW Heritage Office regarding assessments and registers. Also another study on historic signs has been commissioned by Heritage Victoria. It is a study on "Historic Neon in Victoria", prepared by David Wixtead of Heritage Alliance.

### 3 CONSERVATION

#### 3.1 Conservation of signs with cultural significance

Once the cultural significance of a sign has been established an appropriate conservation approach needs to be developed and applied.

Ideally, advice from a heritage practitioner or conservator should be sought to develop the correct conservation approach, particularly if a historic sign is located on a heritage building, is a neon sign with structural issues or is in a conservation area. A conservator can provide the necessary advice for practical conservation methods and future protection of signs. In general, this involves first undertaking an assessment of significance, then formulating a conservation approach suitable for the sign's significance and then developing a scope of conservation works. These rules may be best established in the form of a conservation study. In summary, the study should cover the following:

6. Establish whether a sign is significant, using current methods for assessment (refer to Section 2).
7. Once the significance of a sign has been established, the appropriate form of practical conservation should be determined which reflects the significance of the sign\* and whether the assistance of a conservator is required.
8. Providing the sign is significant and requires conservation, the right approach should be established and a scope of works should be prepared, providing various options regarding the conservation methods and the optimum results expected. This stage should consider the owner's requirements and responsibilities. Another consultant who can undertake the practical conservation work should be engaged to provide initial advice and then to undertake the work.

\*Where a sign is not considered to be significant in terms of the assessment criteria, the sign should be recorded photographically before removal. Similarly, a sign might be significant but there may be no alternative except to remove the sign or paint over it.

#### 3.2 Approach to conservation

Three main conservation approaches for historic signs are proposed in this guideline (A, B & C). Each approach is adaptable and interchangeable and one may follow on from the other. The approaches may require variation, depending on the sign type and owner requirements (D). A technical expert, such as a conservator, can provide the advice for the appropriate practical method for each sign type, particularly as different sign types, such as neon signs or painted signs, will require different practical applications for conservation.

##### A. OPTIMUM CONSERVATION REQUIREMENT

###### Conservation approach

This approach sets out to achieve optimum conservation of historic signs. The conservation approach may include the following (but is not strictly limited to):

- develop an appropriate practical conservation strategy and undertake conservation works (refer to example below) following the methodology of the Australia ICOMOS Burra Charter. A heritage practitioner could be engaged to develop the strategy, while a conservator or expert sign writer (or other specialists depending on the nature of the sign, like a stone mason, engineer or metals conservator) should be engaged to undertake the practical work;
- record the historic sign prior to conservation works being carried out. Colour photographs and slides of archival quality- refer to approach C. The archival record should be publicly accessible;
- nominate the historic sign to a heritage register. If it is possibly of State significance and this case has been made it may be included for entry in the NSW Heritage Register or if it is of local significance it may be nominated for entry on a local government environmental planning scheme. Also recognition of a significant sign may be gained by entry to the National Trust of Australia (NSW) Register (although it is non-statutory register, they include signs).

### Practical conservation application

Following on from the conservation approach outlined above, an example of the practical conservation work for painted historic signs may involve:

- Recording. Prior to undertaking conservation works a written report and photographic documentation (refer to approach C) should be undertaken;
- Surface cleaning. Outdoor signs are often dirty, streaky from rain and with deposits of bird droppings, remnants of posters, signs and graffiti. Many paints have a tendency to powder on the surface from exposure to UV. Some paint manufacturers consider this as a benefit because the powder layer washes off and the coating “self cleans”. As rain does not always fall evenly across a vertical surface, the coating sometimes looks streaky. Cleaning with a mild detergent and thorough rinsing can help to even up the streakiness.
- Consolidation of peeling paint. When paint is drying, the film that has formed develops a very fine network of cracks. As the film ages and the paint becomes more brittle from exposure to light and loss of volatile materials, the cracks become wider. If the substrate moves in response to heat or humidity, the cracks, as the weak point of the film, will pull apart, and the paint will lift and flake. Sometimes it is possible to consolidate this type of peeling paint if the paint is not too brittle. Heat or solvents can be used to soften the paint film (careful testing must be carried out to determine which is the best technique for least intervention) and adhesives introduced that can flow behind the flaking and curling paint to enable it to be flattened onto the substrate again. Excess adhesive must be cleaned off the paint surface, as this can attract dirt.
- Separation or isolation layer. Where a sign has been considered to be of significance and has been recorded but is to be painted over, it would be best to put a clear isolation layer on top of the sign, before putting on a new paint layer. This should be a conservation grade acrylic varnish such as ‘Paraloid B67’, soluble in white spirit, or ‘Paraloid B 72’, soluble in acetone or toluene (available through conservation suppliers). This isolation layer should be covered by the new paint layer.
- Apply inpainting (or over-painting) to the separation layer, which is new paint to reconstruct the original sign where paint is missing if this is the desired effect. The new paint should be reversible, using an acrylic paint.

### Notes:

Examples of this practical conservation application are included in Section 3.4.

Where large areas of signs have been overpainted or inpainted with acrylic paint, Dulux advises against putting a new complete coat of commercial UV inhibited varnish coating as the final layer, as the varnish film may contract strongly and pull the more weakly bound lower paint films away from the substrate.

### Definitions:

*Inpainting* – applying paint to the area of loss only, either directly into the void or onto a putty fill occupying the area of loss.

*Overpainting* – painting on top of the original and/or subsequent layers of paint.

The inpainting or overpainting is carried out to reconstruct the missing part of the sign, so that it can be read as it was originally intended. Inpainting or overpainting should be carried out in a paint with medium of different type to the paint of the sign. This would allow easier separation of the layers should the newer paint ever have to be removed. The separation or isolation layer also assists in this process. The principal applies well where there is an oil or distemper painted sign, then an acrylic would be the preferred medium for inpainting. However, it would not be wise to apply oil paint as the inpaint to an acrylic painted sign, it would be more appropriate to apply another acrylic

layer, as the oil paint will form a much harder and more difficult to remove layer. The principal of reversibility is an important consideration.

Where signs are exposed to the elements it is important to try to form an intact film so that water cannot get behind flakes of paint and undermine the bond with the substrate. In this case the area of inpainting is extended by a few millimetres over the edge of the loss onto original paint to effect a seal on the edge of the loss. These edges should have previously been consolidated, so adhesive should be effecting a seal on the underside of the paint surrounding the loss.

## **B. PREVENTION FROM DETERIORATION**

### **Conservation approach**

Where a sign may be considered significant and minimal funds are available, then the prevention of further deterioration and decay should be applied. If possible, this should be a temporary measure until further investigation, assessment and conservation is possible (refer to approach A).

### **Practical conservation application**

The prevention of further deterioration to signs may involve:

- i. recording the sign by photographs and written documentation (refer to approach C);
- ii. monitoring by inspecting regularly for advancing deterioration;
- iii. surface cleaning to remove dust by brush vacuuming or compressed air if the surface is too fragile; and
- iv. shielding from bird droppings by building a temporary ledge at the top of the sign that extends beyond the edge.

## **C. MINIMUM REQUIREMENT FOR CONSERVATION**

### **Conservation approach**

Where the sign has to be obscured to allow for the addition of a new sign, the following requirements could be considered. Advice from a heritage practitioner, heritage authority or local heritage adviser should be sought before any measures are taken which may impact on a sign and its integrity. If the historic sign is significant, it should not be removed.

9. Record the historic signs. This may involve:
  - i. taking archival colour prints and/or slides (due to the graphic nature of signs);
  - ii. written documentation, which includes describing the location, taking measurements, a physical description of the content and condition and colour matches; and
  - iii. placing the record in a public repository or suitable place where it will be recognised.
10. Retention and/or protection by an appropriate method, rather than removal. Physically removing a sign is not recommended. To leave a sign extant will provide greater opportunity in the future to conserve the sign.

### **Practical conservation application**

The protection of painted signs by 'over painting' may involve:

- i. retaining the sign under a layer of protective 'over-paint' (to be UV resilient acrylic). The paint should not damage the existing sign and should be reversible. Overpainting should be prepared following advice from a conservator or undertaken by a conservator; or
- ii. protecting it under a board, allowing some airspace, to shelter it from excessive sunlight or rain.

#### D. VARIATION OF CONSERVATION APPROACHES

If a historic sign is considered significant then a heritage practitioner, heritage authority, local heritage adviser or planner, should provide advice regarding the conservation approach and practical measures (following the guidelines outlined in this document and the accepted Burra Charter methodology for conservation).

- **Signs on the sides of buildings**

In some cases a sign may be exposed on the side wall of a building following the demolition of a neighbouring building and the question may be posed as to who should be responsible for the sign (eg: the HMV sign in Elizabeth Street)? Ownership of the sign is likely to be the problem in this case and all parties should be notified of the sign's existence.

If the significance of the sign has been determined, then it would be preferable to conserve the sign, however this may not be feasible and the minimum requirement would be to record the sign (approach C). The developer of the neighbouring property should protect the sign before continuing work. This would involve overpainting or covering the sign with a board allowing some airspace but enclosure, allowing it to become accessible for future generations (approach B).

- **Old shop signs painted on external walls**

Currently a number of corner shops and suburban shops, particularly in older suburbs of cities are closing down and being bought by private owners for residential use. Old shop signs are under threat of being lost because the temptation to paint over 'untidy' walls or windows is too great for a new owner who does not consider old signs as significant and/or the cost of conservation may not have been considered at the time of purchase. Local councils should encourage the signs to be retained. In these cases signs should not be painted over. For example, the 'ETA' sign on an old shop in Moss Vale has been retained by the new building owner and is complementary to the owner's antique business.

This could also apply to shop window signs. These should be protected from further deterioration and conservation should be encouraged.

- **Name signs**

Again, in this case, new owners are often tempted to remove old signs and replace or cover them with their new sign/s. This practice should be discouraged by planning authorities, particularly where the building and its sign/s are considered significant and integral components, for example Post Office signs should not be removed when Australia Post may have moved from the building. For example old signs on the Sydney GPO are considered to be historically important aspect of the building history and have been retained as part of the new development.

- **Neon Signs**

Neon signs are major structural elements often located on a building. Like many historic signs ownership and maintenance responsibility is questioned. Neon signs are likely to have historic significance and the advice of the NSW Heritage Office should be sought. This was the case with the "Sharpies Golf House" sign in Elizabeth Street, Sydney, which has been retained as an important historic element in the streetscape.



Side of the building: HMV sign obscured by a new building, 1999.



Corner store sign: "ETA", Moss Vale, NSW, 1999.



Name sign: Sydney GPO, "Post Office Communications", 2001.



Neon sign: "Sharpies Golf House", 1998.

### 3.3 Summary of conservation approaches

	Approach	Stage 1	Stage 2	Stage 3
A	Optimum conservation	Engage heritage practitioner and/or conservator to develop conservation strategy.	Undertake assessment of significance. Nominate to a heritage register. Develop schedule of conservation work.	Undertake conservation of the sign.
B	Prevention	Record the sign.	Retain and prevent from further deterioration or decay.	Seek further conservation advice and / or funding for conservation.
C	Minimal	Seek advice from NSW Heritage Office or local heritage adviser.	Record.	Retain and prevent from further deterioration or decay.
D	Variation	Follow an approach outlined above or seek advice from the NSW Heritage Office or local heritage adviser.	–	–

### 3.4 Examples of practical conservation to historic signs

#### 3.4.1 Market signs, Haymarket, Sydney

Conservation works to painted signs were undertaken at the University of Technology, Sydney (UTS) Haymarket Campus in 1999. There were a number of extant painted 'merchant' signs on the old market facade, originally Market No.3, which was retained as part of a new development for the UTS library. The rest of Market No.3 was demolished in 1981. Only a few other market buildings, which made up the 'Sydney Market Group', survived the 'revival' of the Haymarket area. All merchant signs on the remaining market buildings, apart from those on Market No.3, were removed.

The remnant facade of Market No.3 is considered to be of historic significance as it is part of the 'Sydney Market Group' which is recognised by its entry in the Register of the National Estate, the Sydney City Council LEP heritage overlay and the National Trust of Australia (NSW) Register. Apart from having become a rare feature of the original character and vitality of the markets area, the remnant signs contribute to the significance of the facade. They are considered to be of social, aesthetic, technical and historic significance.

Heritage architects were engaged by the owners, UTS, to develop a conservation strategy and works program for the former market signs found on the Quay Street facade of Market No.3's facade. As part of the project, conservators undertook the conservation work to a number of the signs and followed the optimum conservation approach (approach A). However some of the signs along the facade could not be conserved following approach A, and approach B was applied, whereby they were cleaned recorded, an isolation layer applied and overpainted. Others were so far deteriorated that they had to be recorded and left without conservation. Building approval was not required by the Sydney City Council, however the Council encouraged that the signs be conserved as part of the maintenance of the facade. Public safety issues had to be addressed by the conservators during the works.

The signs that were conserved following approach A were in various states of repair, but in each case there was enough physical and documentary evidence to conserve the signs. The evidence included old photographs and the extant physical fabric of paint colour and text. The advice of the original sign writer also assisted the conservators in their work.

Approach A, as described previously, was undertaken on the Market No.3 painted signs and involved:

- recording the extant signs with a written report and photographic documentation;
- surface cleaning of the remnant paint, which gave a better indication of the original colour and the extent of deterioration;
- consolidation of the peeling paint by heat and adhesive;
- application of a separation and isolation layer, using a conservation grade acrylic varnish; and
- inpainting was applied to the areas of missing sign, including the background colour and text.

Where inpainting was applied to the signs, because the original background or text was missing, a colour match had to be made on site. In accordance with the Burra Charter methodology, the colour was selected to be a close match to the original colour, but distinguishable as new on close inspection. The original intent of the signs was achieved by the conservation work.

As part of the project, the heritage architects recommended that waterproofing be applied on the top of the exposed brick facade to prevent deterioration of the brickwork, leading to decay of the conserved signs. They also recommended monitoring of the conserved signs be undertaken on an annual basis and that interpretative panels be installed near the signs so that passer's by could gain a greater understanding of the history and purpose of the old market signs.

The conservation project received a commendation at the National Trust of Australia (NSW) Heritage 2000 Awards.



*Before conservation works to the market signs in Quay Street, Haymarket, 1996.*



*During conservation works to the market signs in Quay Street, Haymarket, 1999.*

### 3.4.2 The Bushells Building, the Rocks, Sydney

As part of the adaptive reuse of the former "Bushells Building" in the Rocks for office accommodation, a conservation strategy was prepared by the heritage architects to retain and conserve the large billboard size sign on the northern facade. The heritage architects engaged conservators to undertake the conservation of the large "Switch to Tea" sign which was funded by the current owners of the Bushells label, Unilever, as it is still a commercially available product. Documentary evidence, including old photographs of the building and other examples of the Bushells "Switch to Tea" advertising campaign, assisted the conservators in the conservation process. The significance of the "Switch to Tea" sign was clearly associated with the significance of the building as a reminder of its original use and approach A was taken to conserve the sign. However, the northern facade of the Bushell's Building had been used for signage throughout the history of the building, as an ideal location for advertising, and investigation of the numerous layers of earlier signs was undertaken before the decision to conserve the most recent Bushells "Switch to Tea" sign was finalised.



The sequence of earlier signs was investigated and the significance of individual sign layers assessed. Documentary investigation and recording of the sign layers was also undertaken. The most intact layer of signage was the “Switch to Tea” sign dating from the 1960s-70s, protected for a period of time under a billboard dating from the 1980s. A colour ladder scrape was carried out at the top left side of the wall, with the intention of leaving this exposed (and conserved) for future reference. However for consistency of visual presentation, the exposed ladder of earlier signs was varnished with Paraloid B72 and covered with Perspex and then overpainted to match the rest of the wall.

Approach A, as described previously, was undertaken on the “Switch to Tea” sign and involved:

- recording the extant “Switch to Tea” sign, and earlier Bushells signs in a selected area, with a written report and photographic documentation;
- consolidation of the peeling paint was difficult in this case, as the remaining paint had become embrittled. It involved removal of already flaked paint and a general impregnation of the entire surface by spraying with an acrylic dispersion;
- surface cleaning of dirt and residual adhesives were removed; and
- inpainting and overpainting was applied (see note below).

**Note:**

Large areas of brown overpaint covered part of the sign (the area not covered by a later addition billboard) which could not be easily removed without causing damage and the conservators decided to overpaint the area and match, or reconstruct, the background colour and the “Switch to Tea” image. The area of the sign that had been previously covered with a billboard was consolidated, cleaned and inpainted with the appropriate colours to continue the design. The extant image was not overpainted.

A new building was proposed to be constructed in front of the southern facade signs, therefore they were recorded photographically and the surface sealed to protect the signs from damp and light, following approach B.

As the 1991 Conservation Plan for the building recommended the conservation of the sign, the building authorities, the Sydney Harbour Foreshore Authority, encouraged and gave approval for the project. The adaptive reuse project of the Bushell’s Building received a UNESCO ASIA-Pacific Award in 2001 and the conserved Bushells sign on the northern facade is a predominant image of the publicity photographs.



*‘Switch to tea’ sign on the northern facade of the Bushells Building before conservation, 1999.*



*The sign following conservation, 2001.*

### 3.4.3 The School of Arts Building, Sydney

The sign on the former School of Arts Building in Pitt Street, Sydney, which advertised its opening hours, was considered to be an important aspect of the social significance of the building. The heritage architect undertaking the School of Arts conservation project engaged a sign writer to undertake the conservation, as the sign was fairly simple in its design, despite its importance and association with the building. The sign was conserved following approach A, and required very little infill or reconstruction of missing paint to allow the sign to be revitalised.



*The "School of Arts" sign before conservation, 1998.*



*The sign following conservation, 2000.*

## **4 NEW SIGNS ON HERITAGE BUILDINGS**

### **4.1 Minimise the impact of new signs**

Generally, the recommended conservation policy is to promote well designed signs which do not detract from the cultural significance of existing historic signs or the aesthetic quality of the individual building or conservation area. A general conservation policy for new signs on historic buildings is to minimise their impact on the cultural significance of heritage buildings and conservation areas.

New signs, building name signs and advertising signs have the potential to detract from the appreciation of a building, townscape, conservation area and landscape. Consideration of the quality, location and design of new signs is needed so that they do not intrude upon the visual quality of the building or its setting. The essential characteristics which make a building significant should remain as visually dominant, while signs and other advertising should be limited to traditional locations.

New signs are an essential part of a business and a commercial reality. The continuation and change of signs on buildings is anticipated as building owners change and the need for new advertising continues. Historical layering of signs will occur and should be allowed, provided they do not adversely damage the significant qualities of a building or the streetscape value.

Documentation showing the exact size, location, materials, layout, lettering, colours and fixing details should be submitted to the appropriate authority for approval.

### **4.2 New signs**

#### **4.2.1 Styles and design**

New signs need not imitate the period of the building, but could be a contemporary interpretation (unless it is a restoration or reconstruction of the existing sign – refer to Section 3).

The design should consider the materials, colours and location of the new sign which should be sympathetic to the building and its architectural form. The wider streetscape context should also be considered.

The architectural and historical character of the building, surrounding buildings and the streetscape must not be compromised by inappropriate design, size and colour scheme of a new sign or signs. Therefore the sign should enhance, reinforce, not detract from, or obscure, any important features of the building. The colours proposed for the new sign should suit the style and period of the building.

#### **4.2.2 Traditional style**

The traditional style is acceptable where a sign is being restored or in conservation areas, or where a general uniformity is required, such as the Rocks in Sydney. A conservator or a traditional signwriter should be employed to undertake the work with the supervision of a heritage specialist.

Traditional lettering styles are well documented in the National Trust of Australia (Victoria) publication 'Lettering and signs on buildings c1850-1890', written by George Tibbetts, 1984.

#### **4.2.3 Contemporary style**

There is more scope for modern lettering and variations when this option is considered. It is also a preferred option because it is less likely to involve conjectural reconstruction or imitation. Refer to Styles and Design above.

#### **4.2.4 Lettering**

Lettering can be painted into a sign area, on to sign boards or be placed individually on to the building in applied materials, such as metal, timber, etc.

The style of lettering used in signs must be appropriate to the architectural period and character of the building and surrounding area. The use of traditional typefaces would be suitable.

Lettering styles of a traditional style or contemporary styling is acceptable. Elaborate lettering or styles and re-creation of lettering is unacceptable. Lettering on heritage buildings, particularly those of with a greater level of decoration and intricacy such as late 19<sup>th</sup> century Victorian and Italianate examples, should be kept minimal in style, materials and placement.

New neon signs and neon lettering should be restricted to small areas of the proposed signage, preferably only within shop windows.

#### **4.2.5 Location**

New signs should be located in areas or elements of buildings that have traditionally been used for signage (refer to diagram in Section 1.5.2). Original and early signs should be kept (refer to the guidelines above) and not be covered or painted over by new signs.

The size of signs should be kept to a reasonable minimum taking into account the architectural elements of the building and the ability to read the sign from a distance. Signs should not obscure distinguishing features of the building.

The location of a new sign for a heritage building should be drawn from the following types of signs:

- Parapet signs;
- Façade bay sign;
- Flush wall sign;
- Awning fascia sign;
- Under awning sign;
- Top hamper sign; and
- Painted or etched window sign.

#### **4.2.6 Controls**

The following controls should generally be applied but each case should be judged on its merit with reference to specific local council guidelines.

- a) The number of signs should be minimal and restricted to the name of the business and/or proprietor, the name of the building (if applicable) and name of the service or products retailed from the premises. Products / advertising not specifically related are not permissible.
- b) Painted signs on windows should be discreet, and not clutter or dominate the shop window.
- c) Signs should generally not be illuminated internally, flashing, pulsing or moving, although illuminated signs may be permitted for retail tenancies within or inside a building only. These signs should only refer to the name and use of the tenancy.
- d) Tenanted buildings should have a directory provided at ground level, so that advertising on the building can be minimised. However, discreet painted signs on upper storey windows for identification of tenants may be permitted at a local council's discretion.
- e) Roof signs and projecting wall signs above awning level should not be permissible.
- f) Fixings should be such that building fabric is not damaged, and that signs may be easily attached and removed.

## 5 REFERENCES

- Auer, M., *'Historic Signs: Resources for Preservation'*, supplement of CRM (Cultural Resources Management) Information Series, Volume 16, No.6, 1993.
- Australian Institute for the Conservation of Cultural Material (AICCM), (1995), *'Survey of Sculpture, Monuments and Outdoor Cultural Material Handbook'*.
- Department of Planning (DOP), Victoria, (1991), *'Outdoor Advertising - An Urban Based Approach'*.
- Department of Urban Affairs and Planning (DUAP), Heritage Council of NSW, (1995), *'NSW Heritage, How to Prepare Archival Records of Heritage Items'*.
- Department of Urban Affairs and Planning (DUAP) and the NSW Heritage Office, *'NSW Heritage Manual'* (1996).
- Department of Urban Affairs and Planning (DUAP) and the NSW Heritage Office, *'Conservation Areas'* (1996).
- Jackson, R., (1996) *'The Conservation of Painted Signs'*, Research Report for the Masters Degree, The University of Sydney Rachel
- Johnston, C., (ed) (1992), *'What is Social Value?'*, Australian Heritage Commission.
- Marquis-Kyle, P, + Walker, M., (1994), *'The Illustrated Burra Charter'*, Australia ICOMOS.
- Outdoor Advertising Association of Australia Inc (AOAA), (1988), *'Planning for Outdoor Advertising'*, Sydney.
- Paddington Development Control Plan, Section 5.2.10 *'Advertising signs on buildings'*.
- Sullivan, S, + Pearson, M., (1995), *'Looking After Heritage Places'*, Melbourne University Press.
- Sydney City Council, (1996), *'Advertising Sign Code'*.
- Sydney Cove Authority (SCA), (1996), *'Sign Policy for the Rocks'*.
- Tasmanian Heritage Council Practice Note No.6 *'Guidelines for new signs (and hoardings) on sites in the Tasmanian Heritage Register'*.
- Tibbets, G., (1984), *'Lettering and Signs on Buildings c.1850-1990'*, National Trust of Victoria.
- Vines, E., *'Streetwise'* National Trust of Australia and the NSW Heritage Office, 1997.
- Wixtead, D., *'Historic Neon in Victoria'*, Heritage Victoria, 2001.